

FIRST 44.7



Sail Fast. Live Well.

 BENETEAU





## The Best Of Both Worlds.

*Racing and cruising - few performance yachts can achieve this delicate combination that brings a winning yacht together with a comfortable ride when off the course. It is this "best of both worlds" that makes the Beneteau First yachts so incredibly popular. And none more so than the First 40.7, winner of the Sydney-Hobart and IMS World Championship among other prestigious races worldwide. So, when these dedicated and experienced First 40.7 owners asked for the same performance and beauty in a larger model, we turned again to the world's leading performance yacht designers at Farr Yacht Design, Ltd.*

*Together with the genius of Farr Yacht Design, and valuable input from sailors, we believe the sleek and elegant First 44.7 is everything they dreamed it would be. It offers exceptional versatility, outstanding value, race course performance, and Beneteau beauty.*

---

F I R S T 4 4 . 7





## Racing For Silver or Cruising To Win.

*Farr Yacht Design has put all their state-of-the-art expertise into the First 44.7 hull and design. The simple and efficient deck will please both racers and cruisers alike. The helm station incorporates a new high-tech wheel and an instrument console to accommodate all your electronics and navigational instruments.*

*Standard equipment on the First 44.7 includes high-tech aluminum winches and a furling genoa with removable drum. Four huge lockers in the cockpit are designed to store plenty of race gear or cruising equipment. And a long cockpit with generous seating is built to comply with IMS and IRC rules.*

*For the racing perfectionists, the First 44.7 offers options like 3 sets of spreaders, rod rigging, deep fin keel, hydraulic backstay adjuster, and a low drag, folding propeller.*

---

F I R S T 4 4 . 7





## Compare This To Pipe Berths.

*While the First 44.7 looks and performs beautifully on the race course, below decks it shines far above others in its class. You'll feel confident entertaining friends in the spacious salon and comfy cabins. The exquisite Beneteau joinery, a worldwide hallmark, is evident in a new pear-toned finish. Fixed hull ports, opening ports, and deck hatches supply plenty of natural light and ventilation.*

*In the elegant salon you'll find an innovative, adjustable, curved settee adjacent to the dinette which can remarkably move out of your way. The commodious and private owner's cabin, with its separate head and shower, is enough to make the most discerning skipper feel right at home.*

*The First 44.7. A dream inspired by current Beneteau owners. A reality for future Beneteau owners. To learn more, contact your Beneteau Dealer today. Or, see the First 44.7 online at [www.beneteauusa.com](http://www.beneteauusa.com)*

---

F I R S T 4 4 . 7

# FIRST 44.7

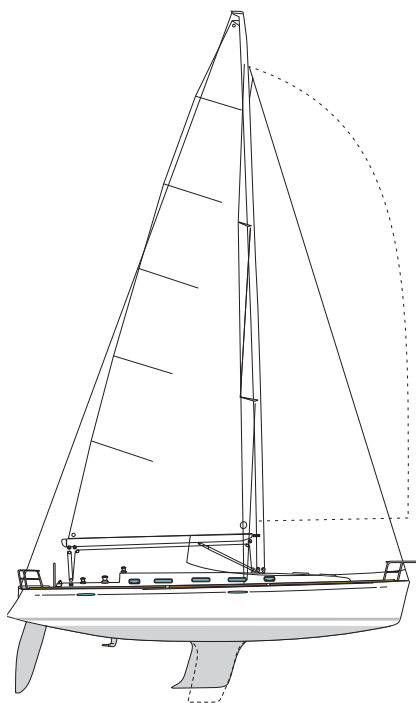

## SPECIFICATIONS

LOA.....	44'10"
LWL.....	37'8"
Beam.....	13'0"
Displacement (light).....	20,126 lbs (approx)
Draft.....	(standard) 6'10" ....(optional) 8'6"
Ballast.....	(light ship) 8,047 lbs
Fuel Capacity.....	53 gal
Water.....	105 gal
Construction.....	Marion, South Carolina, USA
Hull Design:	Farr Yacht Design, Ltd.

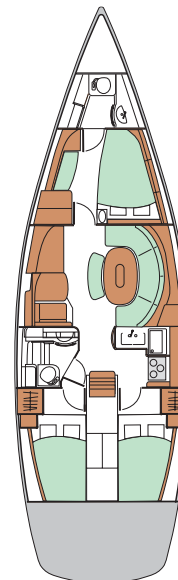

9-04-10k-P



[www.beneteausa.com](http://www.beneteausa.com)



The Sea Demands The Best

Beneteau USA 1313 West Highway 76 Marion, SC 29571  
843-629-5300 [www.beneteausa.com](http://www.beneteausa.com)

The manufacturer reserves the right to alter equipment and specifications without notice. All specifications are approximations and are not contractual in nature.